

CS22

All-in-one



-2°C ÷ +8°C | +30°C ÷ +85°C

Ideal for every need

Combi Station: for every event and for every location.

It is the new all-in-one appliance produced by Friulinox that satisfies every catering need. Its unique strength lies in its practical, and easy to handle, refrigerated drawers for semi-finished or finished foods, and in its heated drawers that keep products warm and ready for service.

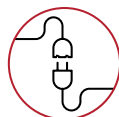

Plug & Play



Modular drawers



Ventilated drawers

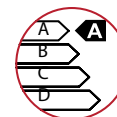

Class A efficiency



All-in-one



Humidity management



Maximum mobility



Customizable rear panel



Technical data

Dimensions (L x P x H mm)	mm	1500 x 700 x 855 mm
Cooling power	W	362 W *
Cooling Temperature Range	°C	-2 °C ÷ +8 °C
Heating power	W	1000 W
Heating Temperature Range	°C	+30 °C ÷ +85 °C
Total electrical power	W	1300 W
Consumption	A	7 A
Power supply voltage	V - Hz	1N AC 230 V - 50 Hz
Refrigerant - Type		R290
Refrigerant - Quantity	g.	70
Climate class		5
Energy rating		A
EEI / 24h		22
kW / 24h	Kw	1,17
Volume	lt.	63

(*) Evap. temperature: -10°C / Cond. temperature: +45°C

special voltages and frequencies available on request

GENERAL CHARACTERISTICS

- All-in-one appliance with drawer compartment for storage at -2°C ÷ +8°C, and drawer compartment for holding at +30°C ÷ +85°C
- Mono body construction with AISI 304 stainless steel interior and exterior finish
- Moulded cell bottom with rounded edges for the highest degree of hygiene
- N° 2 refrigerated drawers (max. height 200 mm)
- N° 2 heated drawers with moisture extraction system (max. height 200 mm)
- Full extension drawers with special Fullerer stainless steel telescopic slides
- Worktop thickness 40 mm
- Insulation thickness of 60 mm, made of high-density polyurethane foam, totally CFC-free
- Equipment provided on wheels for ease of movement even outdoors

REFRIGERATING UNIT

- Evaporator positioned on the side to ensure correct uniformity of cold distribution
- Evaporator with anti-corrosion cataphoresis treatment
- Hot gas defrosting system
- Automatic condensation water evaporation device without power supply
- Environmentally friendly refrigerant R290
- Energy class A

REFRIGERATED COMPARTMENT CONTROLS

- Capacitive control board with temperature set function, HACCP alarms, temperature range -2°C ÷ +8°C

HEATING UNIT

- Heated system with ventilation to ensure correct temperature uniformity
- Integrated thermal safety system

HEATED COMPARTMENT CONTROLS

- Capacitive control board with temperature set function, temperature range +30°C ÷ +85°C

GUARANTEE

- 2-year warranty from the date of installation, subject to submission of the installation report

Coast Distributors Pty Ltd
 Ph: (02) 9524 1234 / 1800 688 590
 PO Box 288, Unanderra, NSW 2526
sales@coastdistributors.com.au
www.coastdistributors.com.au

OPTIONAL - TO BE REQUESTED WHEN ORDERING

- **C3F:** REFRIGERATED 3 DRAWER ADDITION. Drawer 1 height = 100 mm. Drawer 2 and 3 height = 150 mm
- **C3F:** EXTRA 3 HOT DRAWER ADDITION. Drawer 1 height = 100 mm. Drawer 2 and 3 height = 150 mm
- **KFOCS:** ADDITIONAL COMBI COVER - FRIULINOX
- **KPFOCS:** ADDITIONAL COMBI COVER - CUSTOMISED

EXTRA ACCESSORIES THAT CAN BE INSTALLED FOLLOWING PURCHASE

- **KBG:** GN 1/2 - 1/3 - 1/6 CONTAINER SUPPORT KIT
- **RA10:** SERVICE SHELF WITH 1 SHELF (1000 X 300 X 300 H)
- **RA210:** SERVICE SHELF WITH 2 SHELVES (1000 X 300 X 600 H)
- **KFOCS:** COMBI COVER KIT - FRIULINOX
- **KPFOCS:** COMBI COVER KIT - CUSTOMISED

Coast Distributors Pty Ltd
Ph: (02) 9524 1234 / 1800 688 590
PO Box 288, Unanderra, NSW 2526
sales@coastdistributors.com.au
www.coastdistributors.com.au

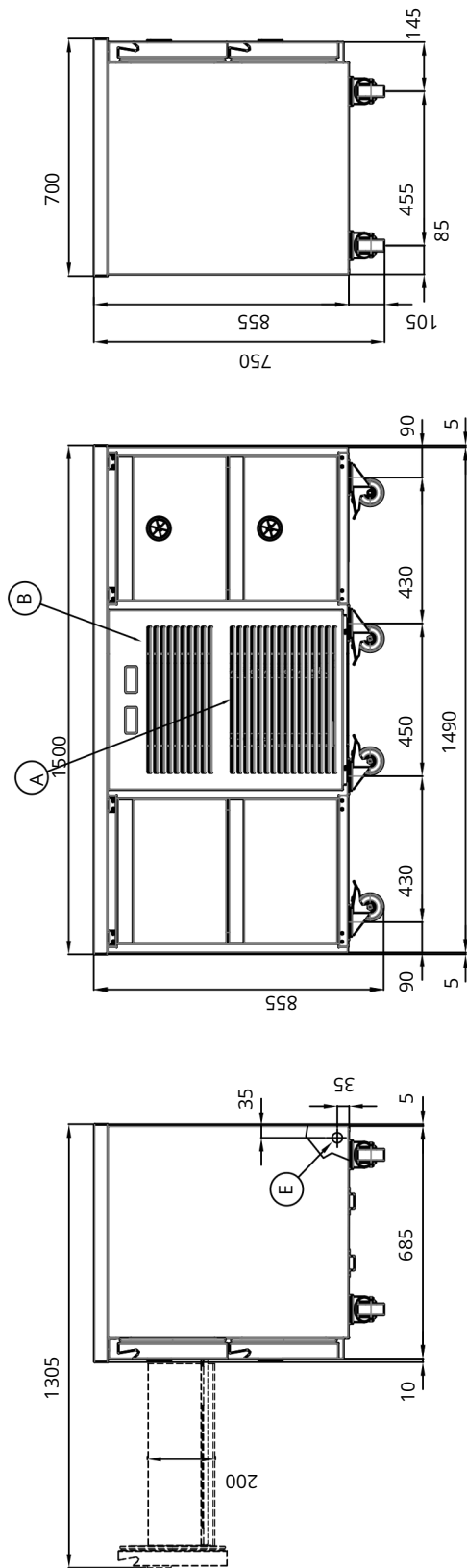

DIMENSIONI mm

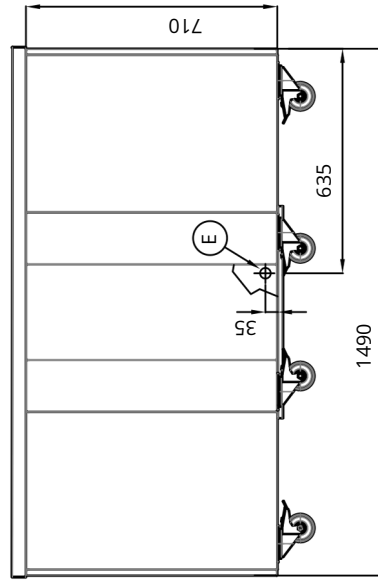

A	CONDENSATION AIR INTAKE
B	CONDENSATION AIR EXHAUST
E	ELECTRIC POWER SUPPLY CABLE INLET

The data reported in this document is to be considered non-binding. The company reserves the right to make changes at any time, without prior notice.



03.11.2022