



# Double door upright

ice storage bins

## Features

Designed for safer and more sanitary ice access

- industry exclusive SmartGATE ice shield controls the flow of ice to reduce spills and limit contact with ice
- locks in three positions and returns easily to full down position – even when bin is full
- better access to safely loosen congealed ice
- no bending into bin means more sanitary ice removal with a scoop or shovel

Fresher ice

- first ice in is first ice out

Ice compatibility

- compatible with all ice types, including customer preferred Chewblet® ice
- dual access doors allow for dispensing two different ice types with use of center partition accessory

Durable, user friendly construction

- full stainless bin exterior
- corrosion-resistant poly bin liner
- heavy duty “stay-open” PowerHinge™ door hinge – easy one hand open and close without door catches
- molded-in gasket never needs to be replaced

Easy installation

- comes assembled, simply screw in legs
- ice access door assembly may be removed easily for installation through doorways

Includes:

- custom-cut stainless tops for most popular ice machines
- 82 oz plastic ice scoop

Industry exclusive SmartGATE ice shield



## Accessories

- SmartCART75™ ice cart
- Center bin partition Ice paddle and hanging bracket
- Ice rake
- Plastic ice shovel
- Additional carts and accessories

Coast Distributors Pty Ltd  
PO Box 288 Unanderra NSW 2526  
Ph: (02) 9524 1234  
E: [sales@coastdistributors.com.au](mailto:sales@coastdistributors.com.au)  
[www.coastdistributors.com.au](http://www.coastdistributors.com.au)

## Specification

Maximum bin capacity <sup>1</sup>	see model table below
<b>W1</b> Width	see model table below
<b>D1</b> Depth <sup>2</sup>	see model table below
<b>D2</b> Depth with lower door assembly (easily removed for installation access)	20.32 cm
<b>D3</b> Depth with door fully extended	add 47.0 cm
<b>H1</b> Height <sup>3,4</sup> (adjustable) w/ legs	see model table below
<b>H2</b> Bin sill height	48.3 cm
<b>H3</b> Height lower section	see model table below
Required door access	see model table below
<b>L1</b> Drain <sup>5</sup>	1.00" FPT, center of bin bottom
Ice compatibility	all ice types including Chewblet ice
Shipping weight	see model table below
NOTE: For indoor use only	

**SHORT FORM SPECIFICATION:** Ice storage bin to be Follett model \_\_\_\_\_ with industry-exclusive SmartGATE ice shield. Bin to hold approximately \_\_\_\_\_ kg of ice. Construction to be welded steel shell and frame. Exterior finish to be stainless steel front, sides, back and bottom. Bin liner to have non-corroding polyethylene walls and stainless steel bottom. Bin insulation to be non-CFC polyurethane foam, bonded to shell and liner for added structural strength. Bin top to be stainless steel custom-cut for specific ice machine(s) to be used. Lower door assembly to include non-corroding polyethylene ice door access assembly, polyethylene lift door with PowerHinge door hinge to eliminate gasket and latches, and inner SmartGATE ice shield to positively control ice flow into ice door access assembly area and reduce spillage. Entire lower door assembly to be easily removable for installation through narrow doors. Where used, upper inspection windows to be of molded double-wall plastic to increase durability and minimize meltage and condensation. Bin to have 15.24 cm legs, adjustable to 18.42 cm. Bin drain to be 1.00" FPT rigid PVC. NSF-listed.

### Warranty:

Follett LLC warrants to the original end user that the cabinet exterior, including the top and trim, and the interior liner will be free of corrosion for 5 years from the date of installation. Date of installation shall not exceed 90 days from date of shipment. Parts and labor for corrosion repair within this 5 year period are covered under this warranty. All other integral components are covered against defects in material and workmanship under normal use and service for a period of 5 years from the date of installation. Date of installation shall not exceed 90 days from date of shipment. Parts and labor for repair within this 5 year period are covered under this warranty. Removal of ice machine to service bin and any labor costs incurred are expressly excluded from this warranty.

## Dimensional drawing

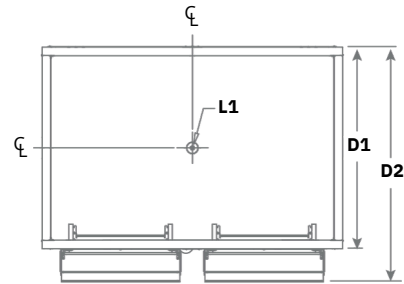
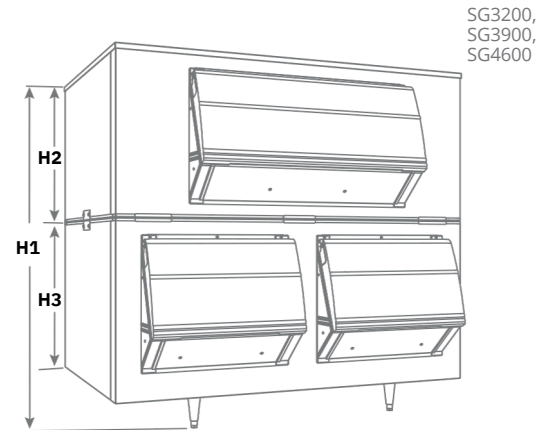
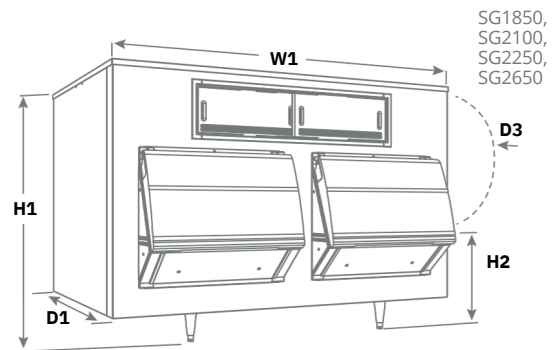

SmartCART and PowerHinge are trademarks of Follett LLC.  
Chewblet, Follett and SmartGATE are registered trademarks of Follett LLC, registered in the US.  
Follett reserves the right to change specifications at any time without obligation. Certifications may vary depending on country of origin.

Model	Maximum bin capacity kg <sup>1</sup>	Cubic Volume cu m	Width - W1 cm	Depth 2 - D1 cm	Height <sup>3,4</sup> w/legs - H1 cm	Height upper section - H2 cm	Height lower section - H3 cm	Required door access <sup>4</sup> cm	Approximate ship weight kg
SG1850-96	848	1.68	243.8	78.7	129.5	N/A	N/A	81.3	205
SG2100-72	957	1.90	182.9	101.6	144.8	N/A	N/A	104.1	221
SG2250-72	1021	2.02	182.9	121.9	128.3	N/A	N/A	124.5	235
SG2650-72	1202	2.38	182.9	101.6	168.9	N/A	N/A	104.1	259
SG3200-72	1470	2.90	182.9	121.9	176.5	80.0	83.8	88.9	346
SG3900-72	1787	3.54	182.9	121.9	207.0	109.2	83.8	111.8	379
SG4600-72	2105	4.17	182.9	121.9	236.2	109.2	113.0	119.4	409

### Notes:

- 1 Computed on cubic volume of bin. Does not reflect cart capacity or voids that can occur due to pyramiding.
- 2 Add 20.32 cm to depth (D) for door assemblies (easily removed for installation access).
- 3 Special top required for ice machines weighing more than 454 kg. Add 5.38 cm to height. Contact factory.
- 4 Required clearance for installation access through doors (may require removal of door assembly).
- 5 Follett recommends installation of a floor drain with grate with all ice storage bins.

Coast Distributors Pty Ltd  
PO Box 288 Unanderra NSW 2526  
Ph: (02) 9524 1234  
E: sales@coastdistributors.com.au  
www.coastdistributors.com.au