

MODEL:

HyGenikx HGX-T-30-S

HYGENIKX+



HyGenikx 'S' range Air and Surface Sanitisation unit – designed for toilets and restrooms, changing and locker room areas. Covers 30m².

Area of Use: General
Colour finish: Titanium
Lamp Type: RED (HGX-30-S)
Range of Cover: 30m²

FEATURES & BENEFITS

- Uses proven UVC technology to improve air quality, extend shelf-life of fresh food, and control odours
- Targets and kills biological hazards, including Salmonella, Escherichia coli (E. coli), Norovirus and other primary sources of infections
- Laboratory tested and proven to eliminate harmful Listeria and remove up to 99.99% of viruses, including Coronavirus. For more information visit: <https://www.mechline.com/hygenikx-testing>
- Eliminates bacteria, viruses, moulds, fungi and volatile organic compounds (VOCs), both in the air and on exposed surfaces, even in the hardest to reach places
- Fully tested and environmentally compliant
- Low power consumption, 9-13W
- Easy to change lamp (and battery), requires no onsite engineer
- Power via a plug that allows flexible installation and easy connection to existing isolated socket or fused spur

TECHNICAL INFO

- Combines technologies: Germicidal Oxidation, Germicidal Irradiation, Dual waveband Plasma Quatro
- Lamp (and battery) requires replacement every 12 months to ensure peak efficiency
- Unit dimensions: 400 x 135 x 110mm
- Rated voltage: 230V
- Operating voltage: 220-230V
- Uninterrupted supply – 24 hour operation required. High level
- 1m (usable length) power cable with plug to be connected to suitably isolated socket or fused spur.
- EC declaration of conformity
- CE and UKCA mark
- Low Voltage Directive (LVD) 2014/35/EU
- Electromagnetic Compatibility Directive (EMC) 2014/30/EU
- Manufactured in accordance with European standards Produced under the control of our comprehensive BSI ISO
- 9001:2015 Quality Management System (certificate FS 616985)
- Class II certified for electrical insulation

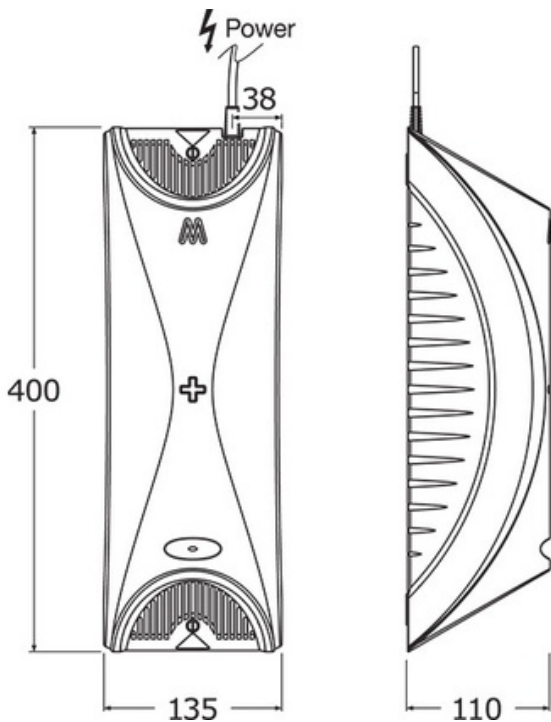

Dimensions are in millimeters.
 If a Cad file is required please visit www.mechline.com.