

Double door Ice·DevIce™

ice storage, dispensing and transport systems



Gravity ice dispense eliminates scooping



Accessories

- Additional carts and accessories

Features

Designed with speed, safety and sanitation in mind

- elevated ice storage bin uses gravity to dispense ice through a chute 7 times faster than scooping
- dispensing directly into a cart eliminates scooping by hand to help prevent cross contamination
- better access to safely loosen congealed ice
- no bending into bin means more sanitary ice removal without a scoop or shovel
- industry exclusive SmartGATE™ ice shield locks in three positions and returns easily to full down position

Fresher ice

- first ice in is first ice out

Ice compatibility

- compatible with customer preferred Chewblet® ice and cube ice
- dual access doors allow for dispensing two different ice types with use of center partition accessory

Durable, user-friendly construction

- full stainless bin exterior and base
- corrosion-resistant poly bin liner and custom-cut stainless steel top
- heavy duty “stay-open” PowerHinge™ door hinge – easy one hand open and close without door catches

SmartCART™ 75 ice cart fits through narrow aisles

- oversized back wheels for easy maneuverability
- the two SmartCART 75 ice carts hold 68 kg in six Totes™ ice carriers
- wide variety of other carts available

Easy installation

- comes with ice access door assembly attached to body of bin
- drain elbow with 1.00" (2.54 cm) barb fitting provided

Includes:

- custom-cut stainless steel top
- two SmartCART 75 ice transport carts, each with three removable Totes ice carriers (refer to chart on reverse for other configurations)
- 82 oz plastic ice scoop
- paddle and rake tool set with hanging bracket

Coast Distributors Pty Ltd

Ph: (02) 9524 1234 / 1800 688 590

PO Box 288, Unanderra, NSW 2526

sales@coastdistributors.com.au

www.coastdistributors.com.au



Specification

| | |
|--|---|
| Maximum bin capacity ¹ | see model table below |
| W1 Bin width | 182.9 cm |
| D1 Bin depth ² | see model table below |
| D2 Bin depth with door fully extended | add 47.0 cm |
| H1 Bin height ³ (adjustable) | see model table below |
| H2 Bin base height (adjustable) | 62.9 cm |
| H3 Bin base clearance (adjustable) | 54.9 cm |
| Required door access | see model table below |
| W2 Cart width | 54.6 cm |
| D3 Cart depth | 86.4 cm |
| H4 Cart height at front edge | 52.1 cm |
| H5 Cart height with lid up | 98.1 cm |
| L1 Drain ⁵ | 1.00" FPT, center of bin bottom (drain elbow supplied) |
| Dispense rate | up to 2.3 kg per second |
| Ice compatibility | cube ice and Chewblet ice |
| Approximate ship weight | see model table below |

NOTE: For indoor use only

SHORT FORM SPECIFICATION: Ice•DevIce system to be Follett model _____ elevated bin, base and cart system with front ice chute and industry-exclusive SmartGATE ice shield. Bin to hold approximately _____ kg of ice. Exterior finish of bin and base to be full stainless front, sides, back and bottom. Bin liner on all models to be heavy-duty, non-corroding polyethylene. Bin liner to have non-corroding polyethylene walls and stainless steel bottom. Bin top to be stainless and custom-cut for ice machine(s) to be used. Lower door assembly to include non-corroding polyethylene ice access door assembly, polyethylene lift door with PowerHinge door hinge to eliminate gaskets and latches, and inner SmartGATE ice shield to positively control ice flow into ice access door assembly area. Entire lower door assembly to be easily removable for installation through narrow doors. Where used, upper inspection windows to be molded double-wall plastic to increase durability while minimizing meltage and condensation. All models to be equipped with flanged, adjustable feet, paddle and rake tool set. NSF-listed.

Warranty:

Follett LLC warrants to the original end user that the cabinet exterior, including the top and trim, and the interior liner will be free of corrosion for the useful life of the product. Parts and labor for corrosion repair are covered under this warranty. All other integral components are covered against defects in material and workmanship under normal use and service for a period of 5 years from the date of installation. Date of installation shall not exceed 90 days from date of shipment. Parts and labor for repair within this 5 year period are covered under this warranty. Removal of ice machine to service bin and any labor costs incurred are expressly excluded from this warranty.

Ice•Device, PowerHinge, SmartCART and Totes are trademarks of Follett LLC. Chewblet, Follett and SmartGATE are registered trademarks of Follett LLC, registered in the US. Follett reserves the right to change specifications at any time without obligation. Certifications may vary depending on country of origin.

Dimensional drawing

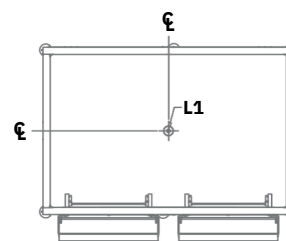
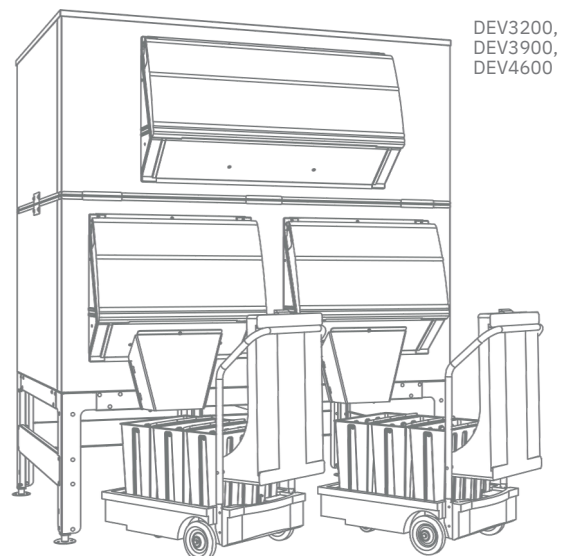
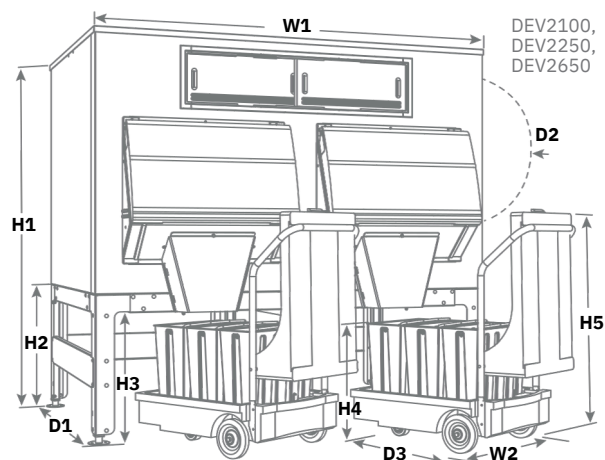

| Model | with SC75 cart | with SC125 cart | with Cambro cart | with bagger kit | Maximum bin capacity kg ¹ | Cubic Volume cu m | Depth ² - D1 cm | Height ³ - H1 cm | Required door access ⁴ cm | Approximate ship weight kg |
|--------------|----------------|-----------------|------------------|-----------------|--------------------------------------|-------------------|----------------------------|-----------------------------|--------------------------------------|----------------------------|
| DEV2100SG-72 | -75 | -125 | -ICS125L | -BG | 957 | 1.90 | 101.6 | 191.8 | 104.1 | 381 |
| DEV2250SG-72 | -75 | -125 | -ICS125L | -BG | 1021 | 2.02 | 121.9 | 176.5 | 116.8 | 344 |
| DEV2650SG-72 | -75 | -125 | -ICS125L | -BG | 1202 | 2.38 | 101.6 | 217.2 | 104.1 | 428 |
| DEV3200SG-72 | -75 | -125 | -ICS125L | -BG | 1470 | 2.90 | 121.9 | 224.8 | 88.9 | 519 |
| DEV3900SG-72 | -75 | -125 | -ICS125L | -BG | 1787 | 3.54 | 121.9 | 255.3 | 111.8 | 573 |
| DEV4600SG-72 | -75 | -125 | -ICS125L | -BG | 2105 | 4.17 | 121.9 | 284.5 | 119.4 | 579 |

Notes:

1. Computed on cubic volume of bin. Does not reflect cart capacity or voids that can occur due to pyramiding.
2. Add 20.32 cm to depth (D) for lower door assembly (easily removed for installation access).
3. Special top required for ice machines weighing more than 454 kg. Add 5.38 cm to height. Contact factory.
4. Required clearance for installation access through doors (may require removal of door assembly).
5. Follett recommends installation of a floor drain with grate with all ice storage bins. Consider cart positioning when locating the drain. Clearance required to pull cart from below bin – minimum 91.4 cm, optimal 101.6 cm.

Coast Distributors Pty Ltd
 Ph: (02) 9524 1234 / 1800 688 590
 PO Box 288, Unanderra, NSW 2526
sales@coastdistributors.com.au
www.coastdistributors.com.au